

Barriers & Safety Fences

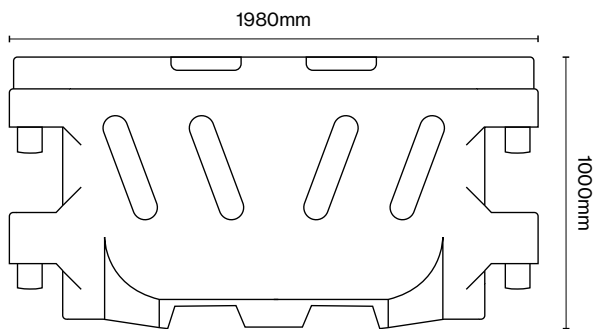

Water Fillable Barriers

These Water Fillable Barriers are manufactured from lightweight yet tough polyethelene providing setup flexibility and ease of movement, yet ultimate strength and durability when filled with water.

- Wind resistant design
- Designated forklift lifting points
- Ezi-twist drainage bung
- Weight: 25kg (empty), 150kg (full)
- Available in either safety orange or white
- 1980mm long x 1000mm high
- 500mm wide at base, 150mm wide at top



CODE	DESCRIPTION	SIZE (mm)
49-WFB-O	Water Fillable Barrier - Orange	1980(L) x 1000(H)
49-WFB-W	Water Fillable Barrier - White	1980(L) x 1000(H)