



## Suggested Uses.

- Physical delineation of traffic lanes.
- Create temporary road layouts
- Separate cycle lanes from vehicle traffic
- Traffic management through worksites

## Benefits.

- Flexible posts twist-lock into the rubber modules, allowing for easy replacement when required.
- Rubber profile keeps vehicles within the lane.
- Quick to assemble and can be installed in 1/3 of the time of traditional delineators - can be permanently fixed or loose-laid for temporary situations.
- Heavy interlocking rubber modules do not move easily when hit even when laid loose, reducing ongoing maintenance.

## Specifications.

Code	49-TS
Description	Flexible Traffic Separator
Material	Recycled Rubber
Height	85mm
Width	250mm
Module Length	Centre - 1000mm / End - 500mm
Module Weight	Centre - 14kg / End - 6.5kg
Fixings	2 per centre module, 1 per end cap

## Components.

49-TSM-B	Centre Module - Black
49-TSM-Y	Centre Module - Yellow
49-TSE-B	End Cap - Black
49-TSE-Y	End Cap - Yellow
49-TSPO	Flexi Post - Orange
49-TSPW	Flexi Post - White

## Fixings.

49-FR12	M12 x 300 Spike
49-FBL	M10 x 100mm Coachscrew and Plug
49-CF12150	M12 x 150mm Concrete Screw

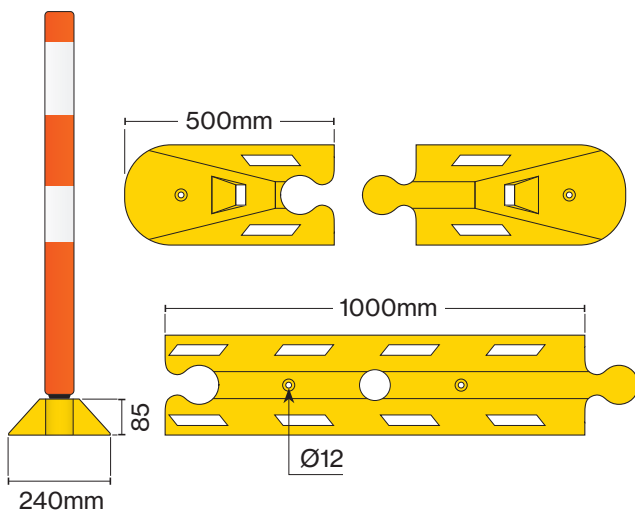

Scan here to view the webpage.

