



Suggested Uses.

- Lane separation & designating cycle lanes on roads
- Traffic management and delineation in carparks
- Separated walkways on worksites

Benefits.

- Manufactured from durable recycled rubber
- Bolt down design allows these to be installed temporarily for trials, or fixed down permanently.
- Single unit with tapered ends.

Useful Tip.

Can be used with or without flexible posts, depending on the application

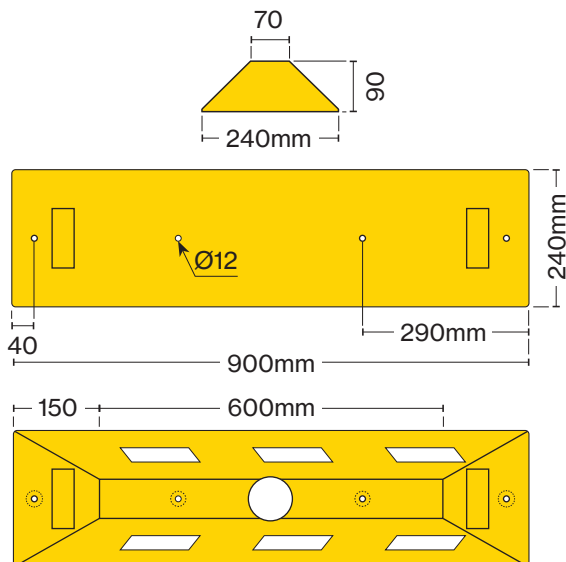

Specifications.

Code	49-TSPOD
Description	Traffic Separator Pod
Material	Recycled Rubber
Height	85mm
Width	275mm
Length	900mm
Weight	11kg
Fixings	4 fixing points per unit

Components.

49-TSPL	Flexi Panel - 750(H) x 150(W)
49-TSPO	Orange Flexi Post - 900(H) x 70(D)
49-TSPW	White Flexi Post - 900(H) x 70(D)

Fixings.

49-FR12-20	12mm x 200mm Rebar Spike (permanent installation)
49-FBL	M10 x 100mm Coachscrew and Plug (temporary installation)
49-CF10100	M10 x 100mm Anka Screw (installation into concrete)



Scan here to view the webpage.

