



Suggested Uses.

- Create exclusion zones or semi-permanent pedestrian walkways through worksites.
- Set up work zone perimeters

Benefits.

- Inbuilt forklift points make it easy to shift and redeploy around sites
- Manufactured in NZ

Specifications.

Code	49-WFB
Description	Water Filled Barriers
Material	Polyethylene
Height	1000mm
Width	500mm
Length	1980mm
Weight	25kg (empty) 150kg (full)
Fixings	

Codes.

49-WFB-W	Water Filled Barriers - White
49-WFB-O	Water Filled Barriers - Orange

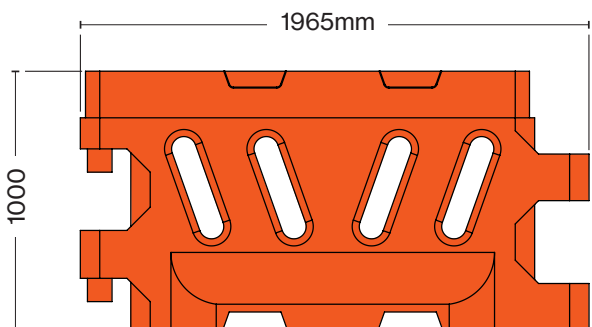
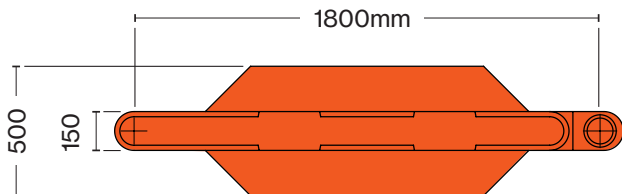

Scan here to view the webpage.

