

# RhinoStop® Single Guardrail

## ASSET & WALKWAY PROTECTION

- **Height:** 625mm
- **Configuration:** Can be configured with a handrail and anti-climb mesh
- **Construction:** Galvanised steel
- **Posts:** Crumple Zone Technology
- **Mounting:** Surface mounted to concrete (Edge-mounted option available)
- **Maximum Post Spacing:** 2m
- **Base Plate:** 32mm thick
- **Fixings:** M20 x 187mm Fischer anchor studs (1 per post)

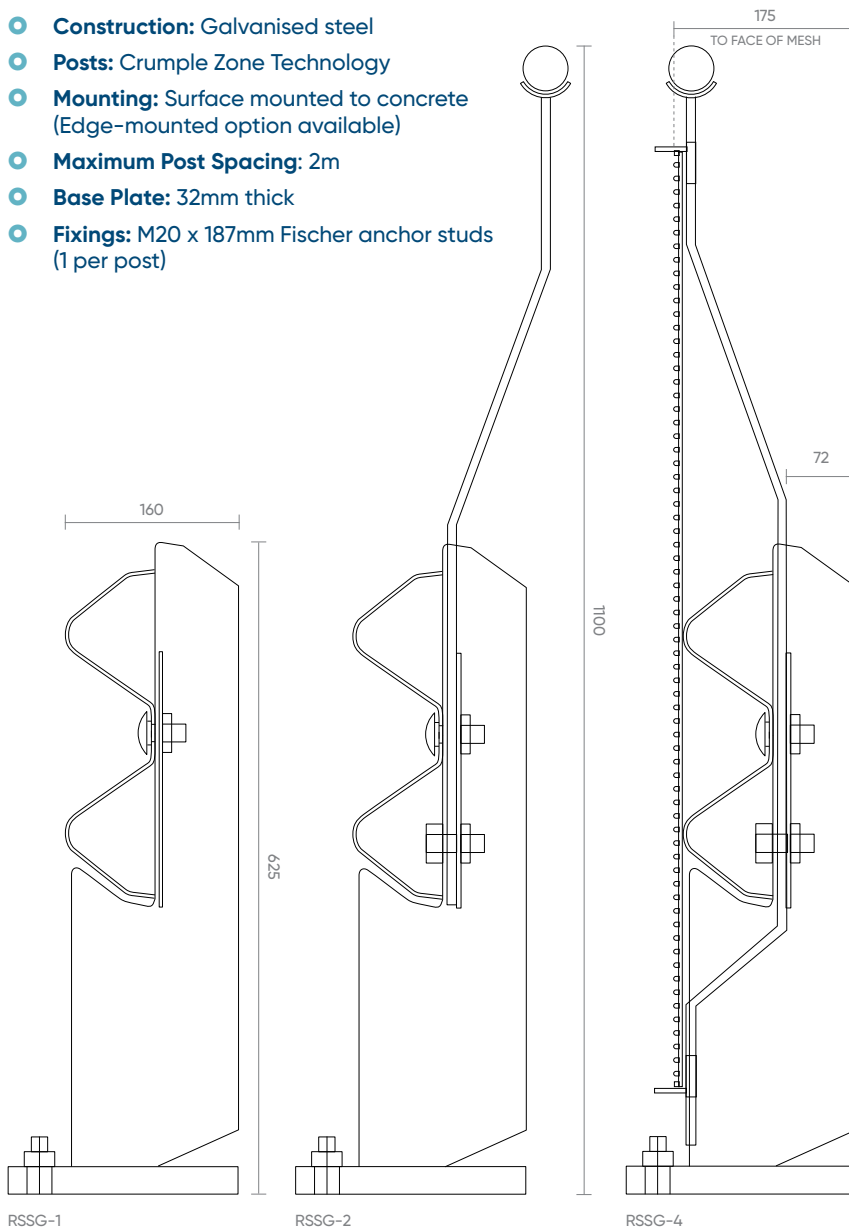

12.9

kJ

## TESTING & CERTIFICATION

- Meets AS/NZS 2890.1 (Off Street Car Parking)
- Meets AS/NZS 1170.1 – Type F 30kN
- Low deflection – just 91mm for a 30kN impact
- Containment of a 1500kg passenger car, impacting 0.5m above floor level, travelling at 15km/h
- Additional crash testing performed to 60kN

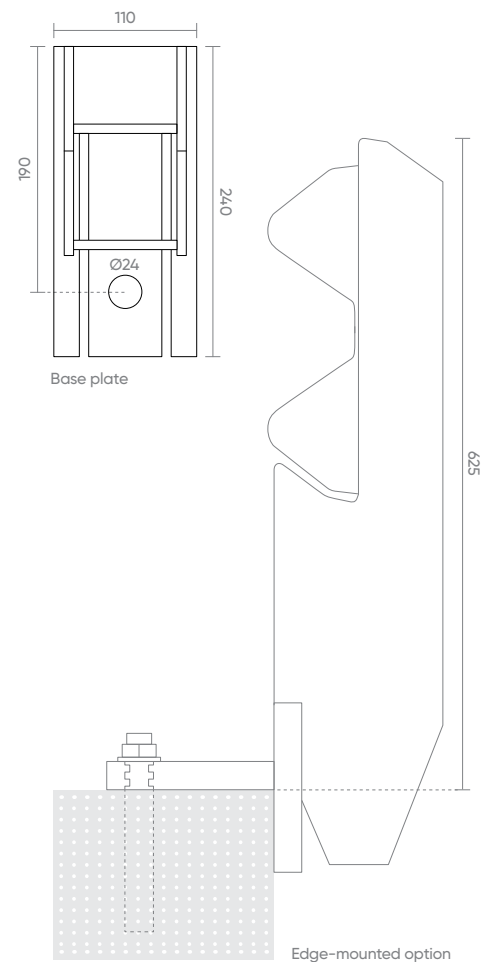

### Options

Code	Description	Height (mm)	Rail Length (mm)	Finish
RSSG-1	Single Guardrail – Type 1	625	Custom	● Galvanised
RSSG-2	Single Guardrail with Handrail – Type 2	1100	Custom	● Galvanised
RSSG-4	Single Guardrail with Handrail and Anti-Climb Mesh – Type 4	1100	Custom	● Galvanised

### End Caps

Options	Finish
Stumpy Bullnose	● Galvanised ● Galv./Yellow
Plastic Sleeve	● Yellow

VIEW ONLINE

