



Suggested Uses.

- Where Inground bollards are required, but need to be removed to allow vehicle access.

Benefits.

- Heavy-duty ground sleeve has a hinged cover that locks to the post with a 10mm padlock and neatly covers the opening when the bollard is removed.
- Available in Galvanised with Safety Yellow powdercoat, or Plain Galvanised.
- Carry handle on side

Useful Tip.

Keep the bollard inserted into the base during installation to ensure the bollard is sitting true.

Specifications.

Description	Steel Inground Removable Bollard
Material	Hot Dipped Galvanised Steel
Height	1318mm (950mm above ground)
Diameter	115mm
Weight	31kg
Wall Thickness	4.5mm

Codes.

1611-085	Inground Removable Bollard Plain Galvanised
1611-086	Inground Removable Bollard Galvanised with Yellow Powdercoat

Installation.

1. Core drill minimum 300mm diameter and 550mm deep or provide footing 400x400x600mm.
2. Consider which direction you wish to have the padlock (or keyhole) facing and ensure the hinge is on that side.
3. Position the ground sleeve accurately so that the top of the cover plate is flush with the surrounding surface and support it while nonshrink flow grout or concrete is added to the hole around the bollard.
4. Finish grout/concrete neatly and level with top of sleeve and surrounding surface as required.

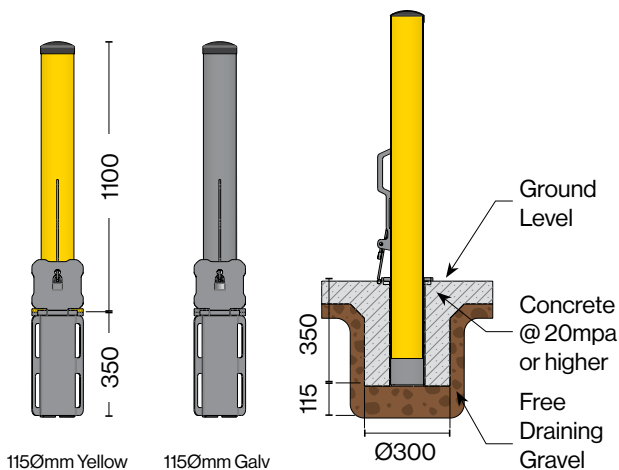

115Ømm Yellow 115Ømm Galv



Scan here to view the webpage.

